

# Who's who in healthcare sustainability?

---

## 1. Global and Health Alliance <http://www.climateandhealthalliance.org/about>

The Global Climate and Health Alliance was formed in Durban in 2011 to tackle climate change and to protect and promote public health. The Alliance is made up of health and development organisations from around the world united by a shared vision of an equitable, sustainable future.

Specifically, Alliance members work together to ensure that health impacts are integrated into global, regional, national and local policy responses to climate change so as to reduce them as far as possible, with a particular focus on reducing health inequalities through mitigation and adaptation. They encourage and support the health sector to lead by example, in mitigating and adapting to climate change.

Awareness is raised of the health threats posed by climate change and the potential health benefits of well-chosen climate mitigation policies in areas such as energy, transport, food and housing.

HCWH, CAHA, OraTaiao and SDU are all members.

## 2. OraTaiao: The NZ Climate and Health Council <http://www.orataiao.org.nz/>

OraTaiao is a group of over 300 New Zealand health professionals concerned about climate change and its health and health equity impacts. Their vision is 'Healthy Climate, Healthy People: through urgent climate change action to bring about a just transition to a safe level of greenhouse gas emissions, and to gain better health, wellbeing and equity for current and future generations'.

Their work involves research, communications, policy, and advocacy initiatives to highlight the health and health equity risks from climate change and the health and equity benefits of climate action. One of the strands of work for OraTaiao is aimed at getting more health organisations engaged and active on the climate-health issue, including embedding environmental sustainability and carbon reduction into health sector organisations.

## 3. Sustainable Health Sector National Network (NZ) <http://www.orataiao.org.nz/National+network>

The New Zealand 'Sustainable Health Sector National Network' is a group of health professionals and others working in the health sector from all around the country who are working together to improve environmental sustainability in the health sector and in health organisations with a focus on reducing greenhouse gas emissions.

The group meets by teleconference on a 6 weekly basis and has many resources to share. The group is affiliated to OraTaiao (NZ Health and Climate Council) and is supported by a number of DHBs.

#### 4. Health Care Without Harm <https://noharm.org/>

Health Care Without Harm is an international coalition of more than 500 organizations in 53 countries, working to transform the health care industry worldwide, without compromising patient safety or care, so that it is ecologically sustainable and no longer a source of harm to public health and the environment.

Members include health systems and hospitals working towards greener healthcare and a healthier environment.

HCWH's areas of work include sustainable healthcare waste management, green building, the substitution of hazardous chemicals used in hospitals with safer alternatives, reducing health care's climate footprint and working with the health sector to advocate for a healthy climate. They provide resource material, expert advice, case studies and tools.

HCWH has regional offices in the United States, Europe, Latin America and South East Asia as well as strategic partners in South Asia and Africa.

Established Practice Greenhealth, Healthier Hospitals Initiative, Global Green and Healthy Hospitals and the Healthy Energy Initiative <http://www.healthyenergyinitiative.org/>

#### 5. Climate and Health Alliance [www.caha.org.au](http://www.caha.org.au)

The Climate and Health Alliance is a coalition of health sector stakeholders who work together to advocate for evidence based response to climate change. Its members include organisations and individuals from a broad cross section of the health sector, with 28 organisational members representing health care professionals from medicine, nursing, physiotherapy, social work and psychology, as well as health care service providers, institutions, academics, researchers, and health consumers.

CAHA works through research, communications, policy and advocacy initiatives to highlight the health risks from climate change and the health benefits of climate action, and promote sustainability in healthcare.

CAHA is a strategic partner of Health Care Without Harm and the lead organisation coordinating the membership of the Pacific region of the Global Green and Healthy Hospitals network. Also they are a HCWH partner in the global Healthy Energy Initiative.

6. Global Green and Healthy Hospitals Network <http://greenhospitals.net/en/>

The Global Green and Healthy Hospitals Network is composed of more than 480 Hospitals, Health Systems and Health Organizations representing the interest of more than 12,500 Hospitals and Health Centers from six continents that are committed to reducing their ecological footprint and promoting environmental health.

The network is based on the members' commitment to implement a comprehensive environmental health framework for hospitals and health systems called the Global Green and Healthy Hospitals Agenda. To become a member, institutions, organisations or health services must commit to working on at least two of the ten action areas in the GGHH Agenda, and sharing their progress through case studies via the online platform and virtual community for members, GGHH Connect.



Global-Green-and-Healthy-Hospitals-Agenda

Health systems, individual hospitals and healthcare services, and health organizations can all join. Once again, GGHH provide a great source of materials, tools, expertise and all the advantages of joining a global network.

7. Practice Greenhealth <https://practicegreenhealth.org/>

Based in the USA, Practice Greenhealth is the source for environmental solutions for the healthcare sector and lends support to create better, safer, greener workplaces and communities.

Practice Greenhealth is a membership and networking organization for institutions and supplier companies in the health care community that have made a commitment to sustainable, eco-friendly practices. Practice Greenhealth provides technical assistance, tools and recognition to its members and with HCWH co-organizes the CleanMed conference each year.

Members include hospitals, healthcare systems, businesses and other key stakeholders involved in greening healthcare to improve the health of patients, staff and the environment.

They provide webinars, educational materials, information and consulting. Practice Greenhealth offers practical and cost-effective programs to its members and continues to educate, motivate and engage the sector to move toward a higher standard of care

#### 8. Healthier Hospitals Initiative <http://healthierhospitals.org/>

Twelve of the largest, most influential U.S. health systems, comprising over 490 hospitals with more than \$20 billion in purchasing power, worked with Health Care Without Harm (HCWH), the Center for Health Design and Practice Greenhealth to create HHI as a guide for hospitals to reduce energy and waste, choose safer and less toxic products, and purchase and serve healthier foods.

The twelve sponsoring health systems have demonstrated their commitment and leadership through coming together to transform their facilities, their systems and the sector to a healthier future.

The three non-profit organizations coordinating the effort are:

Health Care Without Harm, Practice Greenhealth, Centre for Health Design.

(The Center for Health Design (CHD) was formed in 1993 by a small cadre of pioneering healthcare and design professionals committed to advancing a singular idea – that design could be used to improve patient outcomes in healthcare environments. CHD is a far-reaching, international community leading the effort to improve the quality of healthcare facilities worldwide, as well as environments for healthy aging. CHD's mission is to transform healthcare environments for a healthier, safer world through design research, education, and advocacy).

#### 9. Sustainable Development Unit <http://www.sduhealth.org.uk/>

The SDU is funded by, and accountable to, NHS England and Public Health England to work across the NHS, public health and social care system. The SDU is a national unit based in Cambridge working on behalf of the health and care system in England. It was established in April 2008.

They support the NHS, public health and social care to embed and promote the three elements of sustainable development - environmental, social and financial. The Unit is jointly funded by, and accountable to, NHS England and Public Health England to ensure that the health and care system fulfils its potential as a leading sustainable and low carbon service.

The Sustainable Development Unit (SDU) help organisations across health and care to embed and promote sustainable development in order to reduce emissions, save money and improve the health of people and communities.

At an environmental level this includes addressing issues such as energy, travel, waste, procurement, water, infrastructure adaptation and buildings.

More broadly their work expands into the wider long term needs of the health system including adaptation of health service delivery, health promotion, tackling the wider determinants of health, corporate social responsibility and developing new sustainable models of care.

Refer to the following diagram and tables for further information.

Diagram showing interconnectedness of sustainability organizations/global networks

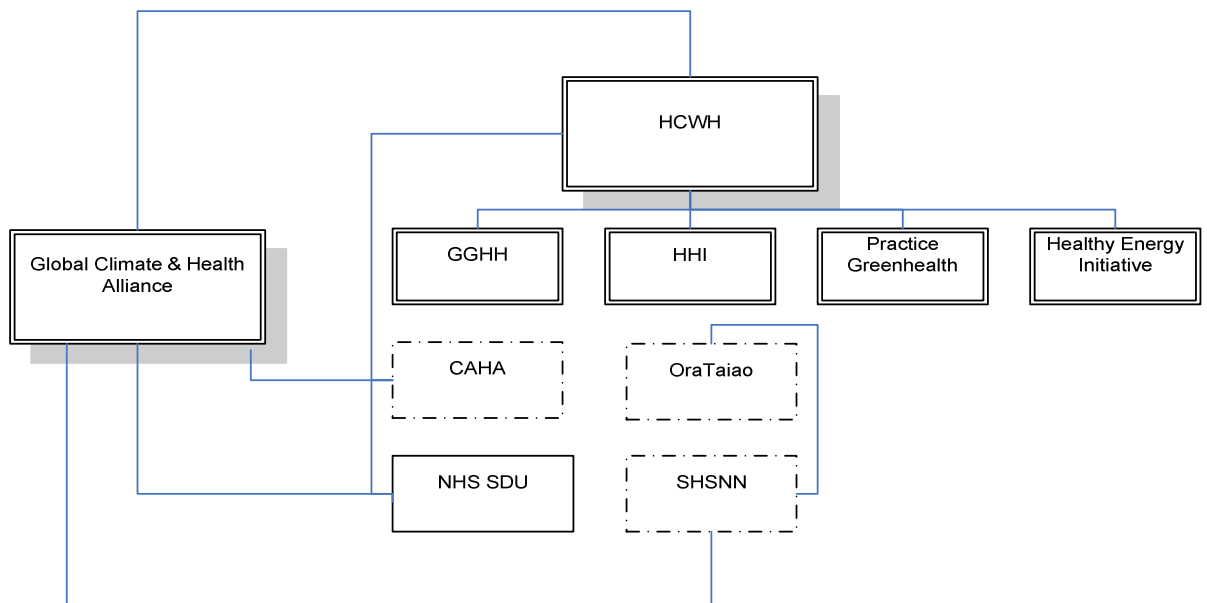

CAHA, OraTaiao and SHSNN- all NZ/Australia based

Summary of organizations:

Name	Purpose	Country of origin/ Sphere of influence	Tools/resources
Climate & Health Alliance	Tackle climate change and to protect and promote public health	Global	Library of documents and materials
OraTaiao: The NZ Climate and Health Council	National network advocating urgent climate change action	N.Z.	Currently setting up a number of case studies/resource material.
Sustainable Health Sector National Network (NZ)	National network of individuals who work in public, social and healthcare in NZ	N.Z.	
Health Care Without Harm	International coalition of healthcare organizations greening healthcare	U.S.- and worldwide	All provide a range of educational webinars, events, case studies, policy documents, and other resources.
Climate and Health Alliance	National coalition advocating for climate action, and promoting sustainable healthcare	Australia – Pacific region, strategic partner of HCWH and lead for GGHH	
Global Green and Healthy Hospitals Network	Global network aimed at reducing the environmental impact of healthcare operations	Global- Sub set of HCWH/HHI	
Practice Greenhealth	National healthcare and suppliers all intent on greening their practice	U.S.- Subset of HCWH	
Healthier Hospitals Initiative	Overarching group of organizations providing guidance and purchasing power	U.S.- Subset of HCWH	
Sustainable Development Unit	Based in England, the SDU support the NHS, public and social systems to become more sustainable	U.K.- partnered with HHI/GGHH	